

Datasheet F-111AI

Mass Flow Meter for Gases



EL-FLOW Mass Flow Meter model F-111AI

> Introduction

Bronkhorst High-Tech model F-111AI Mass Flow Meters (MFM) are suited for precise measurement of virtually all conventional process gases. The MFM consists of a thermal mass flow sensor and a microprocessor based pc-board with signal and fieldbus conversion and a PID controller for optional mass flow control by means of a separately mounted control valve. The IN-FLOW model is of rugged design (IP65) for use in industrial environments or even Zone 2 hazardous areas, with optional ATEX Cat. 3 approval. The mass flow, expressed in normal millilitres per minute or per hour, is provided as analog signal or digitally via RS232 or fieldbus. The flow range and wetted materials are determined depending of the type of gas and the process conditions of the application.

> Technical specifications

Measurement / control system

Accuracy (incl. linearity) (Based on actual calibration)	: $\pm 0,5\%$ Rd plus $\pm 0,1\%$ FS
Turndown	: 1 : 50 (in digital mode up to 1:187,5)
Multiple fluid capability	: • storage of max. 8 calibration curves • optional Multi Gas / Multi Range functionality up to 10 bar abs
Repeatability	: $< \pm 0,2\%$ Rd
Response time ($t_{63\%}$)	: 2...4 sec
Temperature range	: -10...+70°C for ATEX cat. 3 max. 50°C
Temperature sensitivity (nominal range)	: zero: $< \pm 0,05\%$ FS/°C; span: $< \pm 0,05\%$ Rd/°C
Pressure sensitivity	: 0,1% Rd/bar typical N ₂ ; 0,01% Rd/bar typical H ₂
Leak integrity (outboard)	: $< 2 \times 10^{-9}$ mbar l/s He
Attitude sensitivity	: max. error at 90° off horizontal 0,2% FS at 1 bar, typical N ₂
Warm-up time	: 30 min. for optimum accuracy 2 min. for accuracy $\pm 2\%$ FS

Mechanical parts

Material (wetted parts)	: stainless steel 316L or comparable
Pressure rating	: 100 bar abs
Process connections	: compression type or face seal male
Seals	: standard : Viton; options: EPDM, Kalrez
Ingress protection (housing)	: IP65

Although all specifications in this datasheet are believed to be accurate, the right is reserved to make changes without notice or obligation.

Electrical properties

Power supply	: +15...24 Vdc $\pm 10\%$
Power consumption	: max. 320 mA; add 50 mA for Profibus, if applicable
Analog output	: 0...5 (10) Vdc, min. load impedance > 2 k Ω ; 0 (4)...20 mA (sourcing), max. load impedance < 375 Ω
Analog setpoint (for MFM + control valve)	: 0...5 (10) Vdc, min. load impedance > 100 k Ω ; 0 (4)...20 mA, load impedance ~ 250 Ω
Digital communication	: standard RS232 ; options: Profibus-DP®, DeviceNet™, Modbus-RTU, FLOW-BUS

> Ranges (based on Air)

Model	minimum	nominal	maximum
F-111AI-50K	0,4...20 l _n /min	0,4...50 l _n /min	0,4...75 l _n /min
F-111AI-70K	0,6...30 l _n /min	0,6...70 l _n /min	0,6...100 l _n /min

Intermediate ranges are available

Архангельск (8182)63-90-72
Астана +7(7172)727-132
Астрахань (8512)99-46-04
Барнаул (3852)73-04-60
Белгород (4722)40-23-64
Брянск (4832)59-03-52
Владивосток (423)249-28-31
Волгоград (844)278-03-48
Вологда (8172)26-41-59
Воронеж (473)204-51-73
Екатеринбург (343)384-55-89
Иваново (4932)77-34-06
Ижевск (3412)26-03-58
Иркутск (395) 279-98-46
Киргизия (996)312-96-26-47
Казань (843)206-01-48
Калининград (4012)72-03-81
Калуга (4842)92-23-67
Кемерово (3842)65-04-62
Киров (8332)68-02-04
Краснодар (861)203-40-90
Красноярск (391)204-63-61
Курск (4712)77-13-04
Липецк (4742)52-20-81
Магнитогорск (3519)55-03-13
Москва (495)268-04-70
Мурманск (8152)59-64-93
Набережные Челны (8552)20-53-41
Нижегород (831)429-08-12
Казахстан (772)734-952-31

Новокузнецк (3843)20-46-81
Новосибирск (383)227-86-73
Омск (3812)21-46-40
Орел (4862)44-53-42
Оренбург (3532)37-68-04
Пенза (8412)22-31-16
Пермь (342)205-81-47
Ростов-на-Дону (863)308-18-15
Рязань (4912)46-61-64
Самара (846)206-03-16
Санкт-Петербург (812)309-46-40
Саратов (845)249-38-78
Севастополь (8692)22-31-93
Симферополь (3652)67-13-56
Таджикистан (992)427-82-92-69

Смоленск (4812)29-41-54
Сочи (862)225-72-31
Ставрополь (8652)20-65-18
Сургут (3462)77-98-35
Тверь (4822)63-31-35
Томск (3822)98-41-53
Тула (4872)74-02-29
Тюмень (3452)66-21-18
Ульяновск (8422)24-23-59
Уфа (347)229-48-12
Хабаровск (4212)92-98-04
Челябинск (351)202-03-61
Череповец (8202)49-02-64
Ярославль (4852)69-52-93

> Model number identification

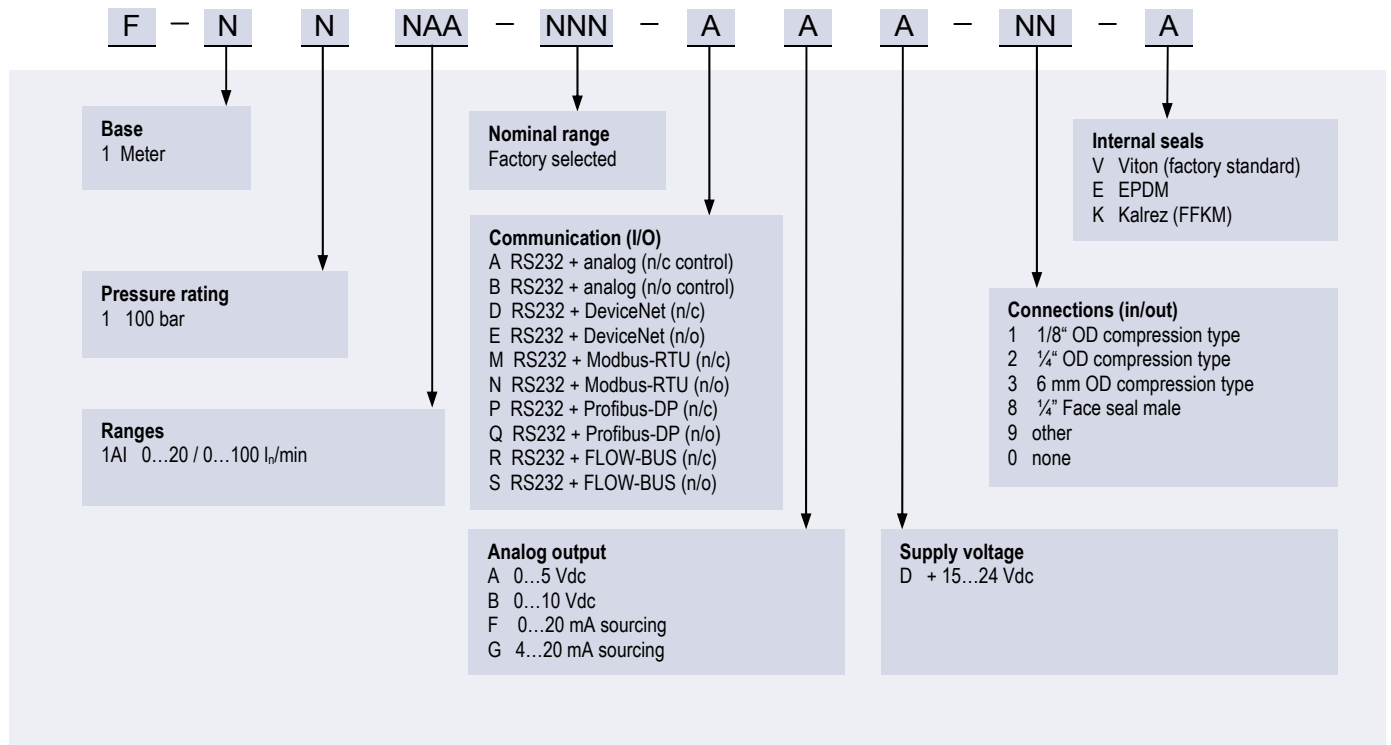

> Thermal mass flow measuring principle

The heart of the thermal mass flow meter/controller is the sensor, that consists of a stainless steel capillary tube with resistance thermometer elements. A part of the gas flows through this bypass sensor, and is warmed up heating elements. Consequently the measured temperatures T_1 and T_2 drift apart. The temperature difference is directly proportional to mass flow through the sensor. In the main channel Bronkhorst High-Tech applies a patented laminar flow element consisting of a stack of stainless steel discs with precision-etched flow channels. Thanks to the perfect flow-split the sensor output is proportional to the total mass flow rate.

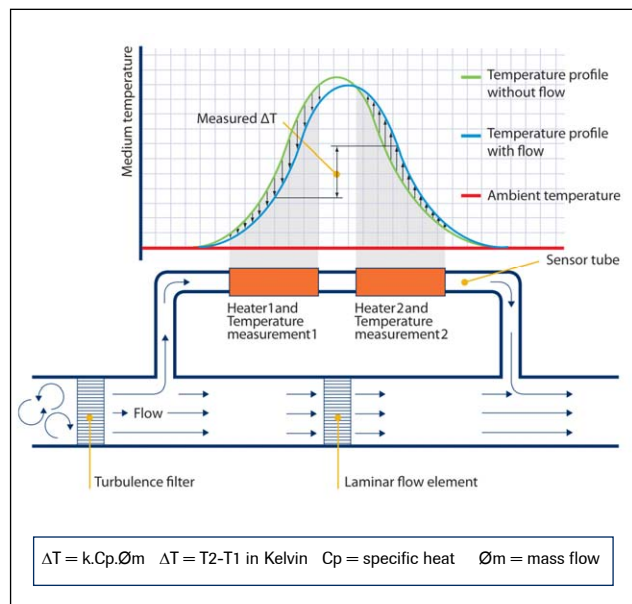

Functional scheme of the thermal mass flow sensor

> State of the art digital design

Today's IN-FLOW[®] series are equipped with a digital pc-board, offering high accuracy, excellent temperature stability and fast response. The basic digital pc-board contains all of the general functions needed for measurement and control. In addition to the standard RS232 output the instruments also offer analog I/O. Furthermore, an integrated interface board provides DeviceNet[™], Profibus-DP[®], Modbus-RTU or FLOW-BUS protocols.

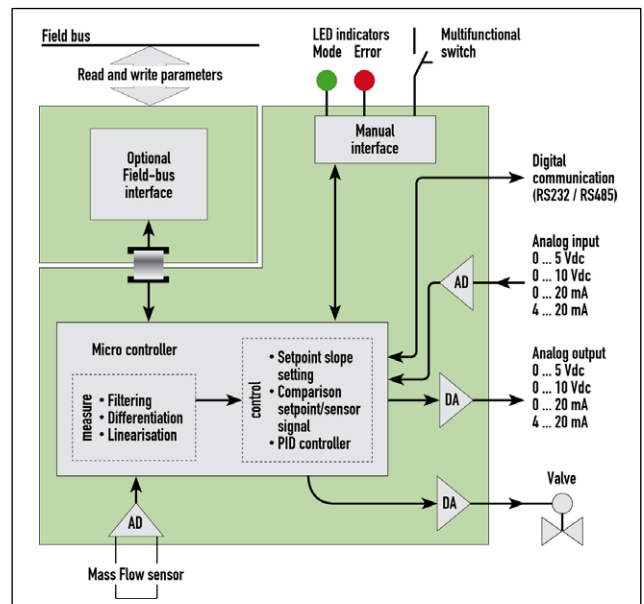

Functional scheme of the digital PC-board

> Hook-up diagram for analog or RS232 communication

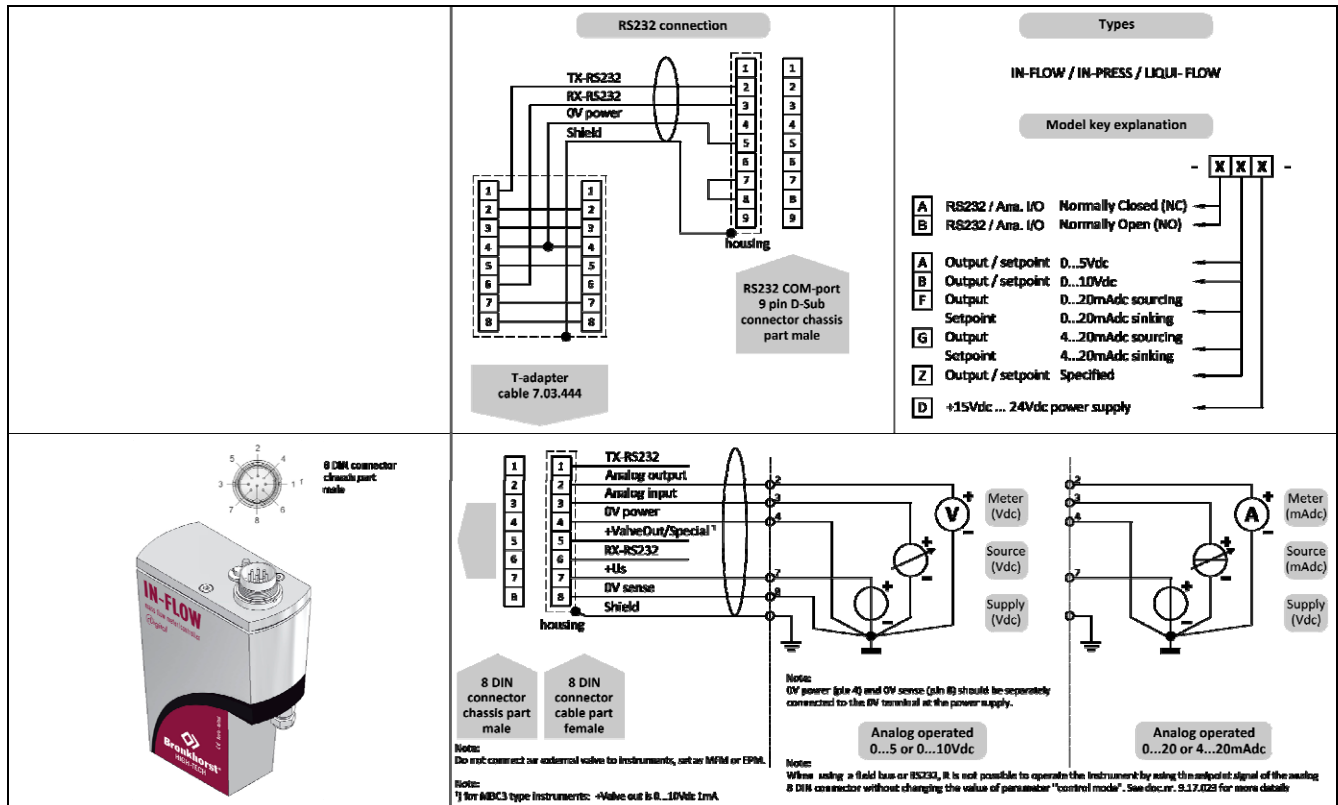

> Hook-up diagrams for fieldbus communication

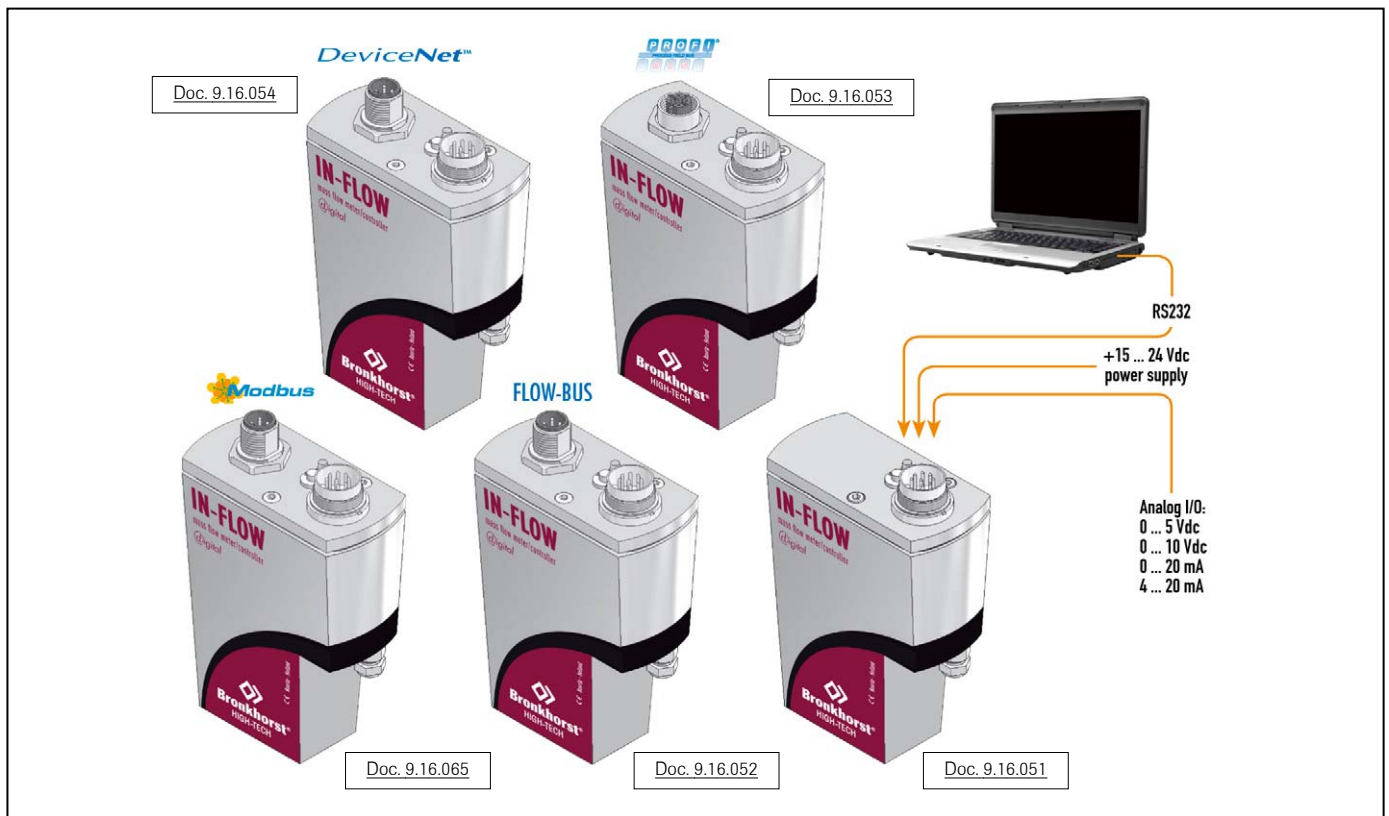

> Dimensions (mm) and weight (kg)

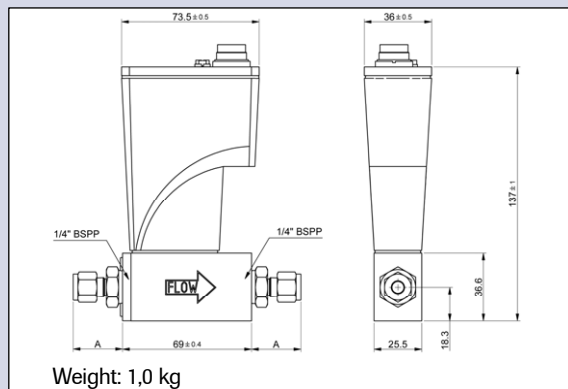

Dimension table adapters (RS-type)

Compression type		1/4" BSPP
		Size A
adapter 3 mm	OD	26.1
adapter 6 mm	OD	28.4
adapter 8 mm	OD	29.4
adapter 10 mm	OD	30.2
adapter 12 mm	OD	32.5
adapter 1/8"	OD	26.1
adapter 1/4"	OD	28.4
adapter 3/8"	OD	29.9
adapter 1/2"	OD	32.7
Face-seal male		Size A
adapter 1/4"	inlet	23.2

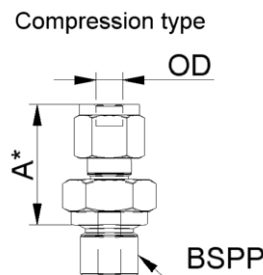

*) Dimension A is typical finger-tight.

> Options and accessories

<ul style="list-style-type: none"> - Multi-Gas / Multi-Range option, with free configuration software. - Free software support for operation, monitoring, optimizing or to interface between digital instruments and windows software. 	
<ul style="list-style-type: none"> - IN-LINE filters for protection against particulates 	
<ul style="list-style-type: none"> - BRIGHT compact local Readout/Control module - E-5700 / E-7000 Power Supply 	
<ul style="list-style-type: none"> - Interconnecting cables for power and analog/digital communication - PiPS Plug-in Power Supply 	
<ul style="list-style-type: none"> - Optional ATEX Zone 2 Cat. 3 protection. Hereto we will furnish extra cover(s) for mechanical impact protection (see pictures), including applicable certificate(s). 	

> Alternatives

<ul style="list-style-type: none"> - LOW-ΔP-FLOW series MFM for low pressure drop applications or corrosive gas service 	
<ul style="list-style-type: none"> - IN-FLOW^{CTA} direct (no by-pass), industrial (IP65) Mass Flow Meter 	
<ul style="list-style-type: none"> - IN-FLOW Mass Flow Controller with integrated control valve 	

Архангельск (8182)63-90-72
 Астана +7(7172)727-132
 Астрахань (8512)99-46-04
 Барнаул (3852)73-04-60
 Белгород (4722)40-23-64
 Брянск (4832)59-03-52
 Владивосток (423)249-28-31
 Волгоград (844)278-03-48
 Вологда (8172)26-41-59
 Воронеж (473)204-51-73
 Екатеринбург (343)384-55-89
 Иваново (4932)77-34-06
 Ижевск (3412)26-03-58
 Иркутск (395) 279-98-46
 Киргизия (996)312-96-26-47

Казань (843)206-01-48
 Калининград (4012)72-03-81
 Калуга (4842)92-23-67
 Кемерово (3842)65-04-62
 Киров (8332)68-02-04
 Краснодар (861)203-40-90
 Красноярск (391)204-63-61
 Курск (4712)77-13-04
 Липецк (4742)52-20-81
 Магнитогорск (3519)55-03-13
 Москва (495)268-04-70
 Мурманск (8152)59-64-93
 Набережные Челны (8552)20-53-41
 Нижний Новгород (831)429-08-12
 Казахстан (772)734-952-31

Новокузнецк (3843)20-46-81
 Новосибирск (383)227-86-73
 Омск (3812)21-46-40
 Орел (4862)44-53-42
 Оренбург (3532)37-68-04
 Пенза (8412)22-31-16
 Пермь (342)205-81-47
 Ростов-на-Дону (863)308-18-15
 Рязань (4912)46-61-64
 Самара (846)206-03-16
 Санкт-Петербург (812)309-46-40
 Саратов (845)249-38-78
 Севастополь (8692)22-31-93
 Симферополь (3652)67-13-56
 Таджикистан (992)427-82-92-69

Смоленск (4812)29-41-54
 Сочи (862)225-72-31
 Ставрополь (8652)20-65-13
 Сургут (3462)77-98-35
 Тверь (4822)63-31-35
 Томск (3822)98-41-53
 Тула (4872)74-02-29
 Тюмень (3452)66-21-18
 Ульяновск (8422)24-23-59
 Уфа (347)229-48-12
 Хабаровск (4212)92-98-04
 Челябинск (351)202-03-61
 Череповец (8202)49-02-64
 Ярославль (4852)69-52-93